

Tool Solution Jib Cranes

Tool Solution Jib Cranes use Gorbel's enclosed track to provide effortless movement and high productivity in work cells. Each jib is designed to be a durable, lightweight and cost effective solution for applications with suspended tools or light duty lifting.

TSJ50: 50 Pound Capacity



The TSJ50 is designed for easy movement of light loads. Its lightweight tie rod style insures easy movement and high performance without giving you more crane than you need for low capacity applications.

With a slim profile and simple installation, the TSJ50 excels in tight work spaces. The small bracket centers of 13-3/16 inches make it ideal for low headroom applications. For free standing models, the crane's slim 4 inch square mast allows installation without a foundation where floor space may be limited. The four-bolt mounting brackets allow for easy adjustment of the boom height, and make conversion to wall or column mounting a simple task.

- Standard spans to 10 feet
- Available as wall or floor mounted
- Up to 180 degrees of rotation
- Uses 250 Series Track
- Free Standing Height Under Boom to 10 feet
- **Available Options:** Rotation lock/adjustable friction brake

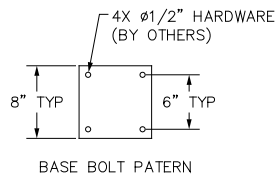
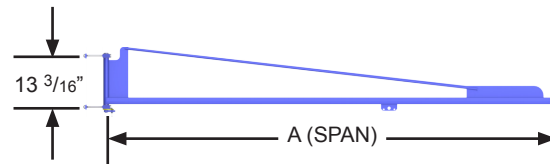
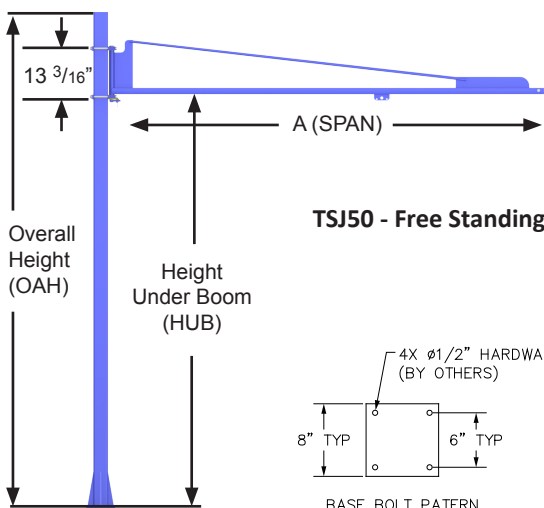

CAPACITY	SPAN (A)	MODEL NUMBER
50#	4'	TSJ50-WM-50-4
	6'	TSJ50-WM-50-6
	8'	TSJ50-WM-50-8
	10'	TSJ50-WM-50-10

CAPACITY	HUB	SPAN (A)	MODEL NUMBER	OAH
50#	8'	4'	TSJ50-FS-50-8-4	9-1/4"
		6'	TSJ50-FS-50-8-6	9-1/4"
		8'	TSJ50-FS-50-8-8	9-1/4"
		10'	TSJ50-FS-50-8-10	9-1/4"
	10'	4'	TSJ50-FS-50-10-4	11-1/4"
		6'	TSJ50-FS-50-10-6	11-1/4"
		8'	TSJ50-FS-50-10-8	11-1/4"
		10'	TSJ50-FS-50-10-10	11-1/4"

Rotation Lock/Adjustable Friction Brake (TSJ50 Only):

The rotation lock allows you to securely lock the boom of the crane in position for storage. The lock features a spring loaded bit that fits into any of 9 positions within the 180° rotation when engaged.

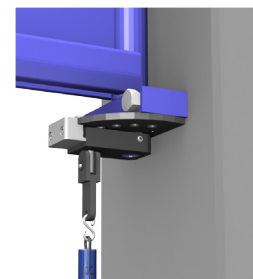

Enclosed Track Jibs

TSJ150: 150 Pound Capacity



For heavier or higher impact applications, Gorbel offers the TSJ150. The lightweight design makes this higher capacity tool jib easy to operate as either a free standing or a column/wall mounted style.

The slim profile of the TSJ150 features bracket centers of only 19-1/2 inches, making it ideal for applications with limited head room. Installing a free standing model in a crowded workspace is made easier with this jib, which does not require a special foundation.

Free standing jib cranes require a 6 inch reinforced concrete floor.

- Standard spans to 12 feet
- Available as wall or floor mounted
- Up to 200 degrees of rotation
- Uses 250 Series Track
- Free Standing Height Under Boom to 10 feet
- **Available Options:** Adjustable friction brake

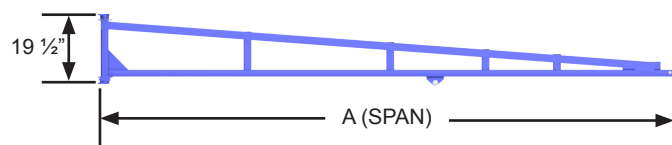
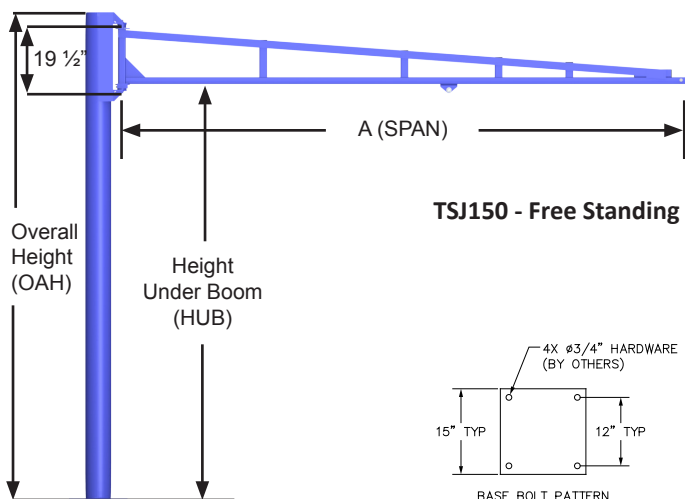

TSJ150 - Wall/Column Mounted

CAPACITY	SPAN (A)	MODEL NUMBER
150#	4'	TSJ150-WM-150-4
	6'	TSJ150-WM-150-6
	8'	TSJ150-WM-150-8
	10'	TSJ150-WM-150-10
	12'	TSJ150-WM-150-12

CAPACITY	HUB	SPAN (A)	MODEL NUMBER	OAH
150#	8'	4'	TSJ150-FS-150-8-4	9-9/16"
		6'	TSJ150-FS-150-8-6	9-9/16"
		8'	TSJ150-FS-150-8-8	9-9/16"
		10'	TSJ150-FS-150-8-10	9-9/16"
		12'	TSJ150-FS-150-8-12	9-9/16"
	10'	4'	TSJ150-FS-150-10-4	11-9/16"
		6'	TSJ150-FS-150-10-6	11-9/16"
		8'	TSJ150-FS-150-10-8	11-9/16"
		10'	TSJ150-FS-150-10-10	11-9/16"
		12'	TSJ150-FS-150-10-12	11-9/16"

Portable Base: Our optional portable base provides a stable base that can be moved easily within your facility. The square steel plate allows you to secure and level your jib with mast mounting hardware and leveling feet. It also features fork pockets for easy relocation by fork truck or pallet jack.

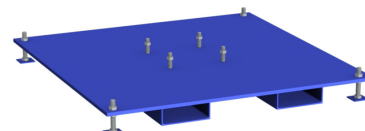

See page 27 for dimensional information.